

Addendum 1 – Pre-bid conference meeting notes and clarifications.

Worcester County Washington Street Parking Lot Expansion – 110 N Washington Street Snow Hill, MD

---

## WORCESTER COUNTY WASHINGTON STREET PARKING LOT EXPANSION

Addendum 1 –

Prebid Meeting Notes of 7/26/21

Prebid Meeting Attendance Roster

Addendum Drawings: J. Stacey Hart & Associates, Inc.

Addendum #1 – Worcester County Washington Street Parking Expansion

Three Sheets

**This addendum must be recognized as received in the final bid due Monday August 9, 2021 by 1:00 PM in the Office of the County Commissioners, Room 1103 – Worcester County Government Center, One West Market Street, Snow Hill, Maryland 21863-1195. All clarifications, specifications and drawings included with this addendum are to be included with the final proposal.**

Prebid Meeting Notes:

July 26, 2021 at 1:00 p.m.

Worcester County Government Center

Notes and Clarifications:

1. The general scope of the project was reviewed regarding the request for general contractor services. Worcester County and J Stacey Hart participants were introduced as follows:
  - a. Bill Bradshaw, Worcester County Engineer
  - b. Stacey Hart, Engineer – J. Stacey Hart & Associates Inc.
2. This project includes the expansion of the existing parking lot on Washington Street on the adjacent vacant property formerly 110 N Washington Street. The house structure on the lot has been razed.
3. Bids are due 9 August 2021. Bids must be delivered as required or will not be considered. See the documents “notice to bidders” and specifications for details.
4. All project information is available on Worcester County website bod board.
5. Bidders are responsible to check and include all addendums in their proposals. All issued addendums will be required to be acknowledged on the Bid forms – Version  (final- date) .
6. Questions must be submitted to William Bradshaw at 410-632-1200 (bbradshaw@co.worcester.md.us) before 2 August 2014 5:00 pm preferably email in writing to facilitate responses from the appropriate party. Answers will follow in the final addendum.
7. The successful contractor will be required to complete a contract with Worcester County referencing the specifications and bid documents. The contractor will be required to include a certificate of insurance with the signed contract and proof of performance bonding, as required.

8. After Contract completion, a “notice to proceed” letter will be issued to the contractor to begin work. Time allotted for the completion of work is 6 months.
9. Pedestrian and public safety and coordinated parking interruptions will be closely monitored and coordination with the County & Town is required. Work areas must include fence/barricades and placement coordinated with the County and Town of Snow Hill.
10. Contractors must supply and maintain dumpster facilities for the construction work. No construction or debris or trash from the renovation project will be permitted in the facility dumpsters.
11. A permit will be supplied by Worcester County for the project covering. The permit will be with the Town of Snow Hill and the successful contractor is required to request all inspections with the Town building department. Third party inspections including stormwater are the responsibility of the Contractor.
12. Normal Work schedule: Per the specification and Town ordinance.
13. The contractor must provide licensed land surveyor services for all layout and as-built requirements.
14. The engineer will provide clarification regarding the type of stone to be used on lot perimeter for stormwater purposes.
15. Attendees were encouraged to walk the site after the meeting.

END of section

Worcester County Bid Attendance List  
 Project : Washington Street Parking Lot Expansion  
 Date : July 26, 2021 @ 10:00 AM  
 Location : Worcester County Government Center – 1 West Market Street Snow Hill, MD – First Floor Board Room

Name	Company	Phone	Email
Bill Bradshaw	Worcester City	410-632-1000	bbradshaw@co.worcester.md.us
RYAN CAHILL	TERRA FIRMA OF DELAWARE	302 846 3350	ryan@terrafirmacorp.com
STACEY HART	JSH, INC.	410-430-481	STACEY@JSTACEYHART.COM
Scott Whit	A-DEL	443-880-3165	swhitt@A-DEL.com
RICH MAZUL	CHESAPEAKE TURE LLC	302-922-1317	RICHT@CHESAPEAKETURE.COM

Addendum 1 – Pre-bid conference meeting notes and clarifications.

Worcester County Washington Street Parking Lot Expansion – 110 N Washington Street Snow Hill, MD

## **DRAWINGS**

**J. Stacey Hart and Associates (Sheets attached)**

**Sheet 1 of 3 – Grass Swale Clarification**

**Sheet 2 of 3 – Pea Gravel Diaphragm (Level Spreader) Detail & Concrete Entry  
Way and Apron Detail**

**Sheet 3 of 3 – Stormtech System Base Thickness Revision**

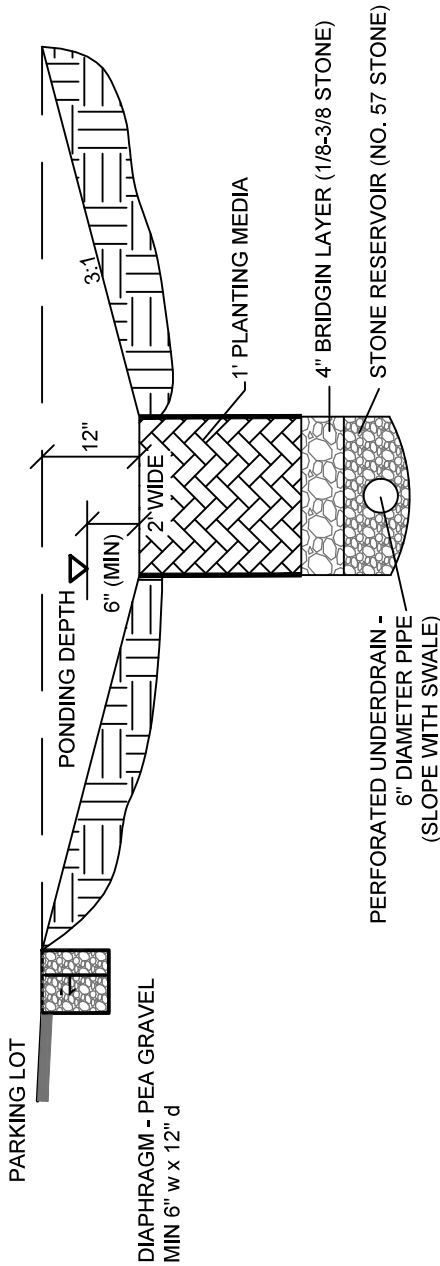

# GRASS SWALE

NTS

## SWALE INSPECTION, OPERATION & MAINTENANCE - EXISTING & PROPOSED

### INSPECTION

- DURING PLACEMENT AND BACKFILL.
- UPON COMPLETION OF FINAL GRADING AND ESTABLISHMENT OF PERMANENT STABILIZATION.

### OPERATION & MAINTENANCE

- DURING THE ESTABLISHMENT PERIOD, INSPECT CHANNEL AFTER EVERY RAINFALL.
- AFTER GRASS IS ESTABLISHED, CHECK THE CHANNEL AT REGULAR INTERVALS AND AFTER EVERY HEAVY RAINFALL EVENT. IMMEDIATELY MAKE REPAIRS. IT IS PARTICULAR IMPORTANT TO CHECK THE CHANNEL OUTLET FOR BANK STABILITY AND EVIDENCE OF SCOURING.
- REMOVE ALL SIGNIFICANT SEDIMENT ACCUMULATIONS WITHIN THE BOTTOM OF CHANNEL ONCE IT HAS ACCUMULATED TO 25% OF THE ORIGINAL DESIGN VOLUME IN ORDER TO MAINTAIN THE CARRYING CAPACITY.
- MOW GRASS TO MAINTAIN A HEIGHT OF THREE TO FOUR INCHES.

### ADDENDUM #1

WORCESTER COUNTY  
WASHINGTON STREET PARKING EXPANSION  
SNOW HILL, MARYLAND

JOB NUMBER:  
2017-070

SCALE:  
NONE

SHEET NO:  
1 OF 3

DATE:  
8/3/2021

REVISED:  
N/A

COPYRIGHT © 2021

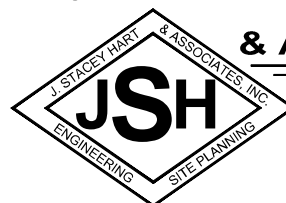

**J. STACEY HART  
& ASSOCIATES, INC.**

POST OFFICE BOX 6  
SNOW HILL, MD 21863  
PHONE: 410-390-8096  
FAX: 877-646-4365

EMAIL: [stacey@jstaceyhart.com](mailto:stacey@jstaceyhart.com)

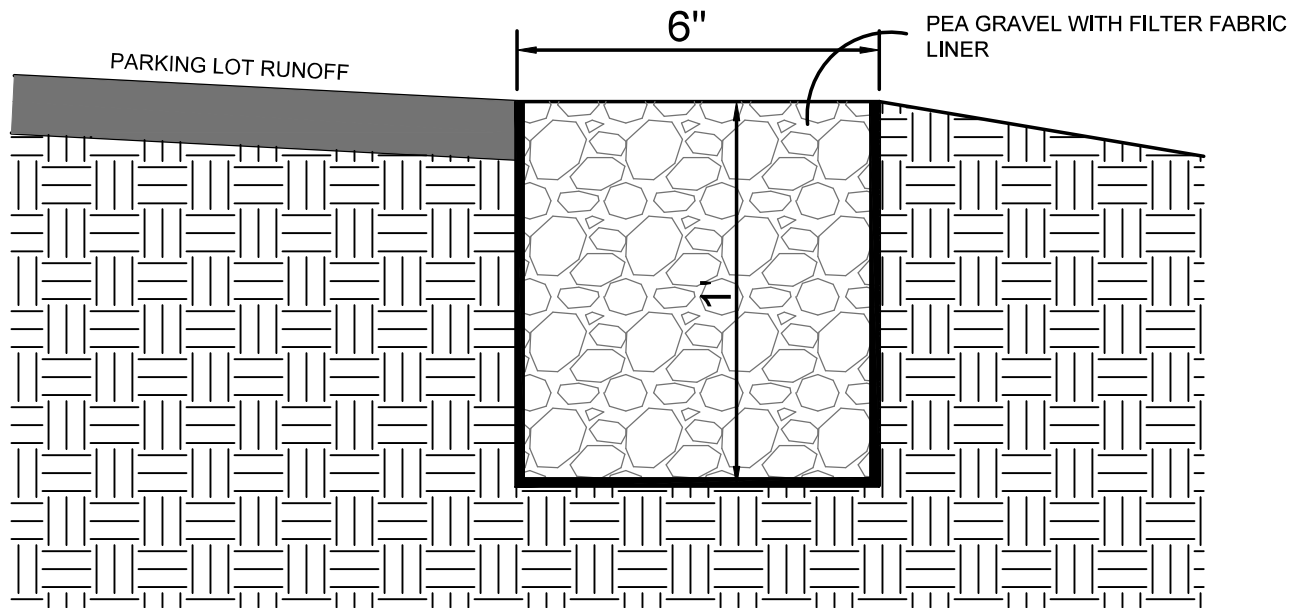

## PEA GRAVEL DIAPHRAGM (LEVEL SPREADER) DETAIL

NTS

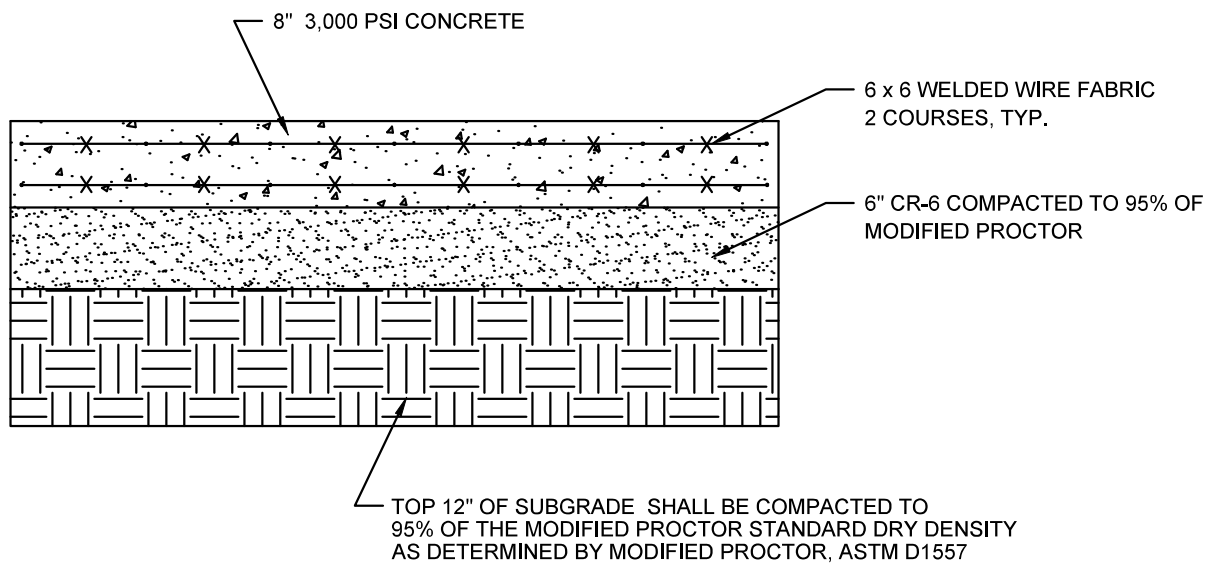

## CONCRETE ENTRY WAY AND APRON DETAIL

NO SCALE

ADDENDUM #1  
WORCESTER COUNTY  
WASHINGTON STREET PARKING EXPANSION  
SNOW HILL, MARYLAND

JOB NUMBER:  
2017-070

SCALE:  
NONE

SHEET NO:  
2 OF 3

DATE:  
8/3/2021

REVISED:  
N/A

COPYRIGHT © 2021

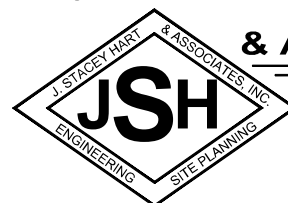

**J. STACEY HART  
& ASSOCIATES, INC.**

POST OFFICE BOX 6  
SNOW HILL, MD 21863  
PHONE: 410-390-8096  
FAX: 877-646-4365

EMAIL: [stacey@jstaceyhart.com](mailto:stacey@jstaceyhart.com)

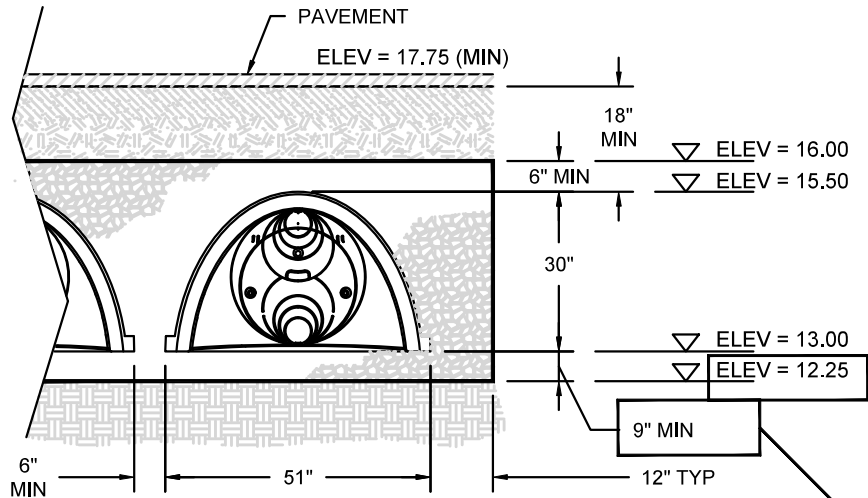

NOTE: BASE THICKNESS HAS BEEN REVISED AND IS 9"  
(DETAIL FROM SHEET JSH SHEET 3)

ADDENDUM #1  
WORCESTER COUNTY  
WASHINGTON STREET PARKING EXPANSION  
SNOW HILL, MARYLAND

JOB NUMBER: 2017-070	SCALE: NONE	SHEET NO: 3 OF 3	DATE: 8/3/2021	REVISED: N/A
-------------------------	----------------	---------------------	-------------------	-----------------

COPYRIGHT © 2021

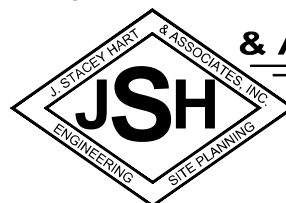

**J. STACEY HART  
& ASSOCIATES, INC.**

POST OFFICE BOX 6  
SNOW HILL, MD 21863  
PHONE: 410-390-8096  
FAX: 877-646-4365  
EMAIL: [stacey@jstaceyhart.com](mailto:stacey@jstaceyhart.com)