

DEPARTMENT OF  
ENVIRONMENTAL PROGRAMS

## Worcester County

GOVERNMENT CENTER  
ONE WEST MARKET STREET, ROOM 1306  
SNOW HILL, MARYLAND 21863  
TEL: 410.632.1220 / FAX: 410.632.2012

LAND PRESERVATION PROGRAMS  
STORMWATER MANAGEMENT  
SEDIMENT AND EROSION CONTROL  
SHORELINE CONSTRUCTION  
AGRICULTURAL PRESERVATION  
ADVISORY BOARD

WELL & SEPTIC  
WATER & SEWER PLANNING  
PLUMBING & GAS  
CRITICAL AREAS  
FOREST CONSERVATION  
COMMUNITY HYGIENE

April 4, 2017

This notification is to advise you that the Department has received and is presently reviewing the following request for a shoreline construction project:

J. Stacey Hart & Associates on behalf of Donald Gelinis – Request No. 2017-34 – Request to remove existing 6' x 25' pier and boatlift and install a new 6' x 25' pier with (1) one boatlift and (1) one double PWC lift. Construction will not to exceed 25' channelward. This project is located at 39 Moonshell Dr also known as Tax Map 16, Parcel 41, Section 4, Lot 160, Third Tax District of Worcester County, Maryland.

The Department in considering this application will make specific findings of fact with regard to the environmental impact, navigational impact, recreational potential, commercial benefit to Worcester County, impact of the proposed construction upon the surrounding neighborhood and upon property values therein, and any other pertinent issues. Approval from the Department does not guarantee approval from any other applicable regulatory agencies.

**If you have an interest which may be adversely affected by the issuance of this permit, you are requested to notify this Department in writing within fifteen (15) calendar days which will end on April 19, 2017.**

Sincerely,

Adam Phipps-Dickerson,  
Natural Resources Specialist

CC: File;  
Dave Bradford, Deputy Director



WORCESTER COUNTY SHORELINE CONSTRUCTION APPLICATION

Request No.: 2017-34 Submission Date: 4/3/17

xx Major Construction (\$150) Minor Construction (\$75)

Written Description of Proposed Improvement (include channelward distance):

remove existing 6x25 dock and boat lift; re-construct new 6x25 pier and install one (1) boat lift and one (1) double PWC lift a maximum of 25' channelward of existing bulkhead face/MHW/MI W

Property Description:

Map: 16 Parcel: 41 Lot: 160 Section: 4 Block: Tax District: 3 Street Address: 39 Moonshell Drive Subdivision: Ocean Pines Dwelling on lot: xx Dwelling under construction: Vacant: Commercial:

Owner: Donald & Mary Gelinus Phone No. 410-746-4470 Mailing Address: 6108 Holly Ridge Ct. Columbia, MD 21044 E-Mail Address: dmgelinas@gmail.com

Contractor: J. Stacey Hart & Associates, Inc. Phone No.: 410-390-8096 Mailing Address: PO Box 6, Snow Hill, MD 21863 E-Mail Address: stacey@jstaceyhart.com

Recorded Adjacent Property Owner: Kevin & Nicole Wimsatt Property Address: 41 Moonshell Drive, Ocean Pines, MD 21811 Tax Map: 16 Parcel: 41 Lot: 161 Section: 4 Block:

Recorded Adjacent Property Owner: Dolores S. Neuland Property Address: 37 Moonshell Drive, Ocean Pines, MD 21811 Tax Map: 16 Parcel: 41 Lot: 159 Section: 4 Block:

As the applicant, I attest that the information presented on this application, site plan and any written documentation attached hereto is known to be accurate. I understand that the proposed shoreline improvement will be constructed to meet or exceed minimum design standards adopted by the Department. Any deviation from these standards will require construction plans sealed by an engineer registered in the State of Maryland. I acknowledge that any falsification of information presented may result in revocation of this approval and of the subsequent Shoreline Construction Permit.

Donald Gelinus Mary Gelinus 3/20/17 Owner/Applicant's Signature Date

\*\*\*\*\*

DEPT. USE ONLY:

Notification Distribution Date: Public Comment Deadline: (15 calendar days) Department Approval Date: Expiration:

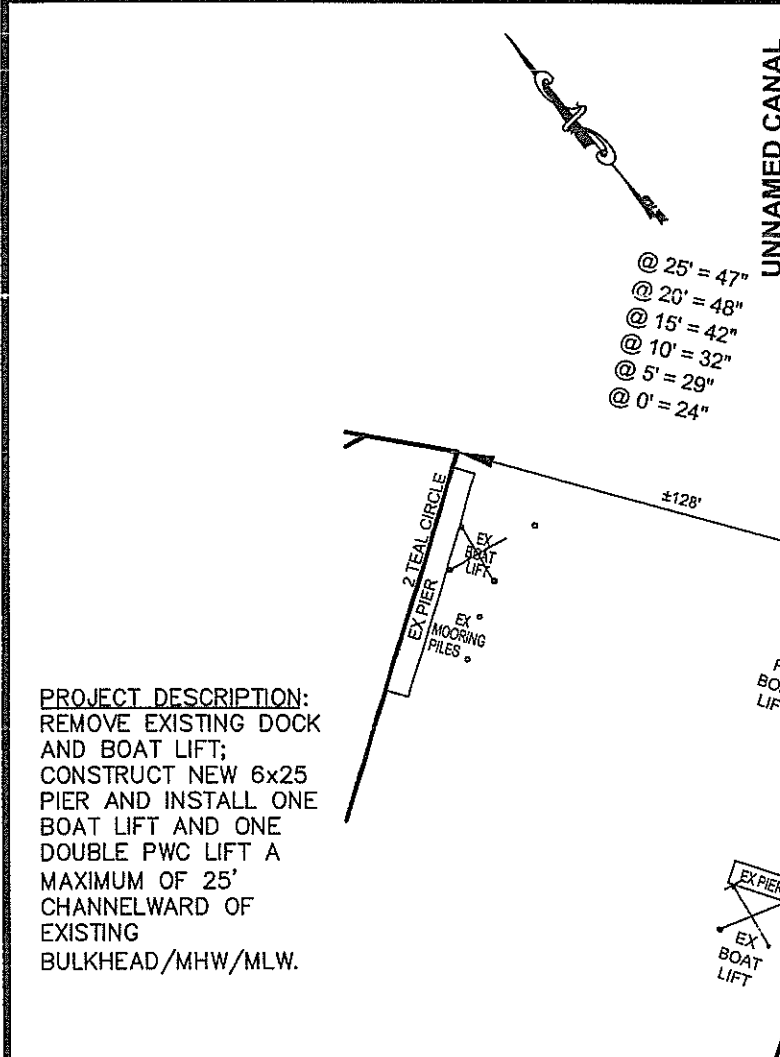
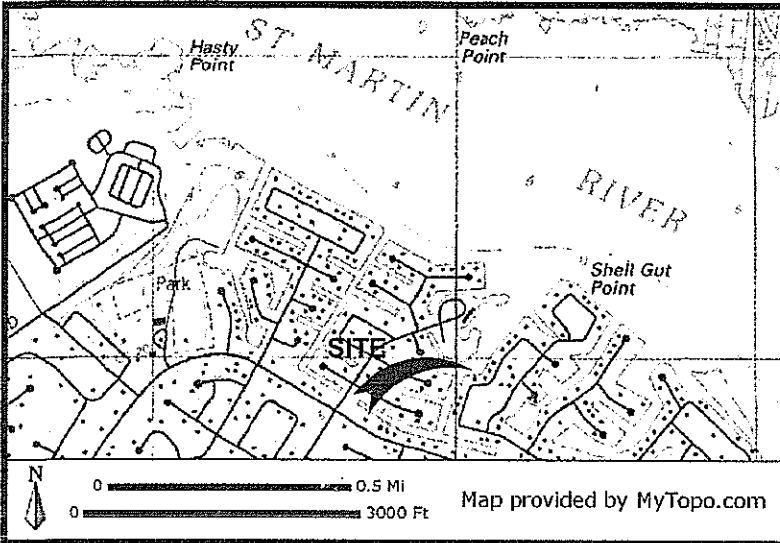

**PROJECT DESCRIPTION:**  
 REMOVE EXISTING DOCK  
 AND BOAT LIFT;  
 CONSTRUCT NEW 6x25  
 PIER AND INSTALL ONE  
 BOAT LIFT AND ONE  
 DOUBLE PWC LIFT A  
 MAXIMUM OF 25'  
 CHANNELWARD OF  
 EXISTING  
 BULKHEAD/MHW/MLW.

**GELINAS RESIDENCE  
 PROPOSED MARINE IMPROVEMENTS  
 39 MOONSHELL DRIVE  
 WORCESTER COUNTY**

**APPLICANT:**  
 DONALD & MARY GELINAS  
 6108 HOLLY RIDGE CT  
 COLUMBIA, MD 21044

LOCATION: OCEAN PINES, SECTION 4  
 WATERWAY: ST MARTIN RIVER  
 WATER DEPTH MEASUREMENTS: 3/21/2017  
 REFERENCED TO MLW 11:30 A.M.

NO SAV'S

TAX MAP: 16  
 PARCEL: 41  
 SECTION: 4  
 LOT: 160

JOB NUMBER: P17-015	SCALE: 1"=50'	SHEET NO: 1 OF 2	DATE: 3/24/17	REVISED: N/A
------------------------	------------------	---------------------	------------------	-----------------

COPYRIGHT © 2017

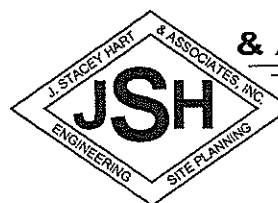

**J. STACEY HART  
 & ASSOCIATES, INC.**

POST OFFICE BOX 6  
 SNOW HILL, MD 21863  
 PHONE: 410-390-8096  
 FAX: 877-646-4365  
 EMAIL: stacey@jstaceyhart.com

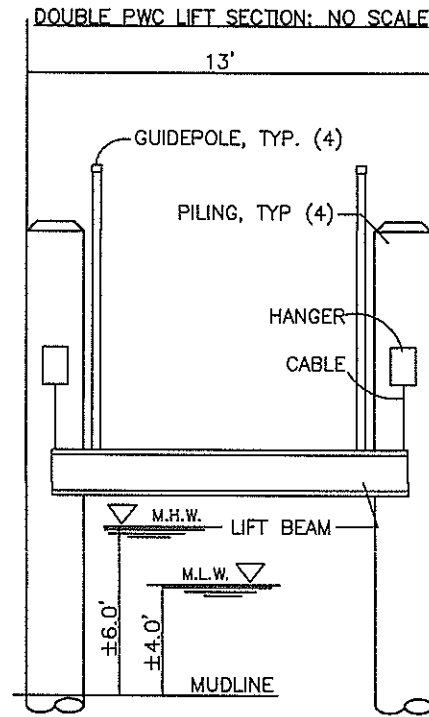
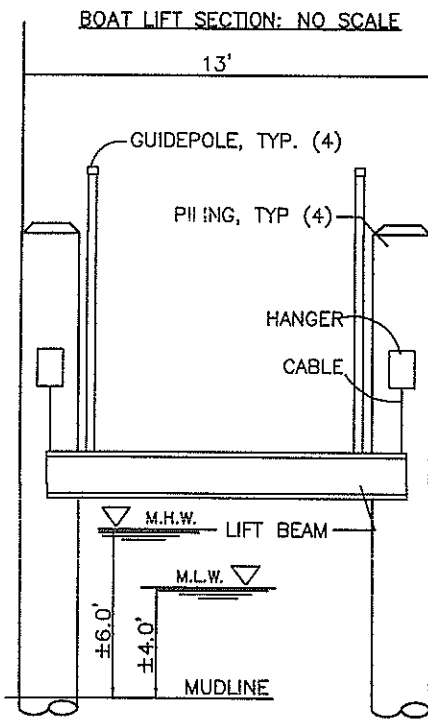

**PIER SECTION: NO SCALE**

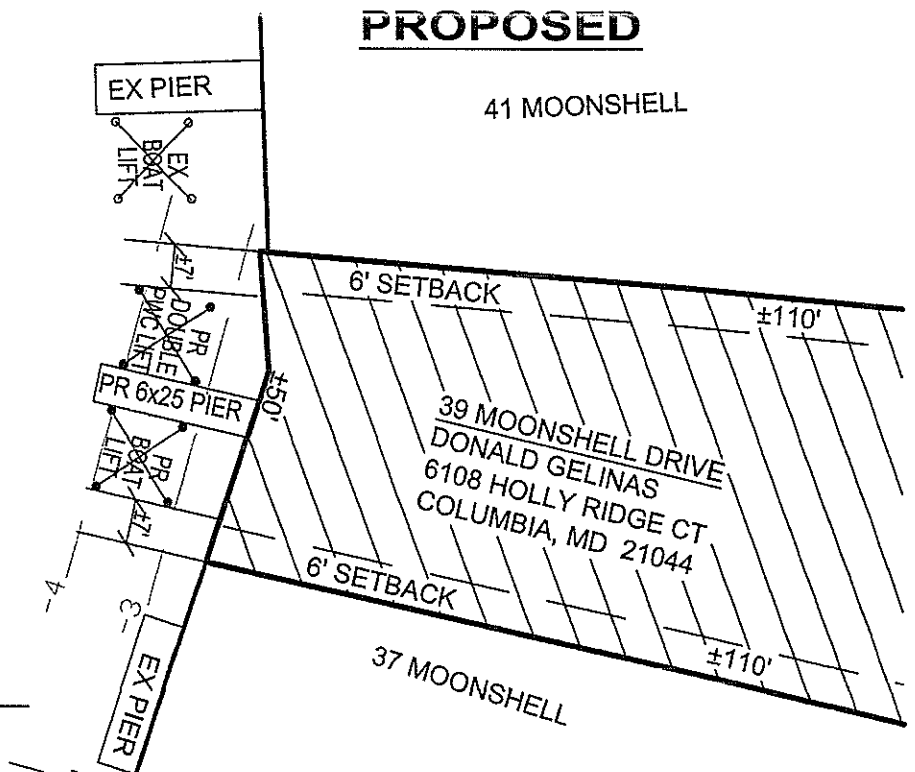
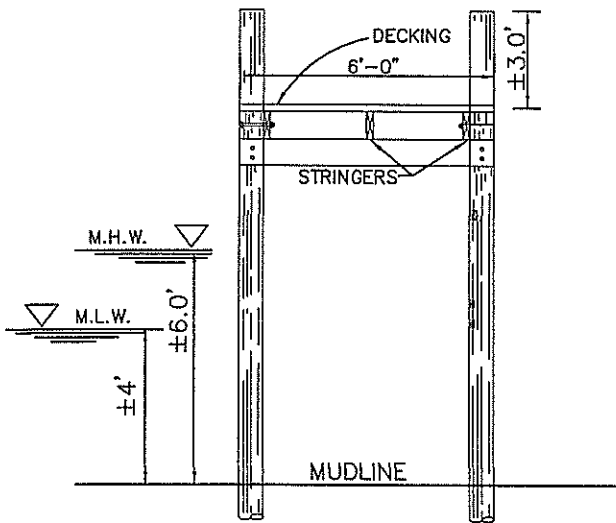

**GELINAS RESIDENCE  
PROPOSED MARINE IMPROVEMENTS  
39 MOONSHELL DRIVE  
WORCESTER COUNTY**

APPLICANT:  
DONALD & MARY GELINAS  
6108 HOLLY RIDGE CT  
COLUMBIA, MD 21044

LOCATION: OCEAN PINES, SECTION 4  
WATERWAY: ST MARTIN RIVER  
WATER DEPTH MEASUREMENTS: 3/21/2017  
REFERENCED TO MLW 11:30 A.M.

NO SAV'S

TAX MAP: 16  
PARCEL: 41  
SECTION: 4  
LOT: 160

COPYRIGHT © 2017

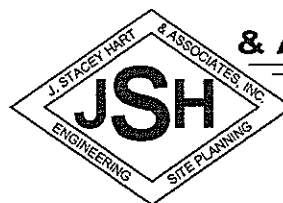

**J. STACEY HART  
& ASSOCIATES, INC.**

POST OFFICE BOX 6  
SNOW HILL, MD 21863  
PHONE: 410-390-8096  
FAX: 877-646-4365

EMAIL: [stacey@jstaceyhart.com](mailto:stacey@jstaceyhart.com)

JOB NUMBER: P17-015	SCALE: 1"=30'	SHEET NO: 2 OF 2	DATE: 3/24/17	REVISED: N/A
------------------------	------------------	---------------------	------------------	-----------------

